



PRODUCT SELECTION DATA

WATER-COOLED VARIABLE-SPEED SCREW CHILLERS WATER-SOURCED VARIABLE-SPEED SCREW HEAT PUMPS



- Low energy consumption
- High reliability
- Safe Design
- Easy and fast installation
- Minimised operating sound levels
- Environmental care
- Designed to support green building design

30XW-VZE/30XWHVZE-A



Nominal cooling capacity 448-1243 kW
Nominal heating capacity 524-1485 kW

The 30XW-VZE/30XWHVZE water-sourced units are the premium solution for commercial and industrial applications where installers, consultants and building owners require maximum quality and optimal performances, especially at part load.

The 30XW-VZE/30XWHVZE units are designed to meet current and future requirements in terms of energy efficiency, versatility and compactness. They feature exclusive inverter-driven screw compressors - an evolution of the proven traditional Carrier twin-rotor screw compressor design. Other features include:

- the new SmartVu™ control
- mechanically cleanable flooded heat exchangers
- refrigerant R-1234ze or R-515B

The 30XW-VZE/30XWHVZE range is splitted into two versions:

- 30XW-VZE for air conditioning applications
- 30XWHVZE for heating applications

As standard, the unit can provide an evaporator leaving water temperature down to 3.3°C, and when operating as a heat pump, it can deliver up to 55°C on the condenser side.



CARRIER participates in the ECP programme for LCP/HP
Check ongoing validity of certificate:
www.eurovent-certification.com

* Evaporator with aluminium jacket shown in the picture not standard - available as special order only

CUSTOMER BENEFITS

Low energy consumption

- The 30XW-VZE/30XWHVZE are designed for high performance both at full load and at part load.
 - Eurovent certified values per EN14511-3:2013: SEPR up to 10.7 and SEER up to 8.8
- High energy efficiency
 - Inverter-driven twin-rotor screw compressors allow precise capacity matching of building load changes and significantly reduce unit power input, especially at part-load.
 - Flooded multi-pipe heat exchangers for increased heat exchange efficiency.
 - Electronic expansion device permits operation at a lower condensing pressure and improved utilisation of the evaporator heat exchange surface.
- Optimised electrical performance
 - All 30XW-VZE/30XWHVZE units comply with class 3 of standard EN61800-3. Category C3 refers to industrial environments. With option 282 category C2 compliance is possible.
 - Inverter-driven motors ensure negligible start-up current (value is lower than the maximum unit current draw)

High reliability

- The 30XW-VZE and 30XWHVZE ranges offer increased global performance as well as Carrier's acclaimed product quality and reliability. Major components are selected and tested to minimize failures possibility, as well as many design choices have been taken in this perspective.
- Inverter-driven screw compressors
 - Industrial-type screw compressors with oversized bearings and motor cooled by suction gas.
 - The inverter is optimised for each compressor motor to ensure reliable operation and easy maintenance.
 - All compressor components are easily accessible on site minimising down-time.
- Refrigerant circuits
 - Two independent refrigerant circuits (from 1000 kW upwards); the second one automatically takes over, if the first one develops a fault, maintaining partial cooling under all circumstances.
 - All components have been selected and tested with R-1234ze refrigerant and R-515B
- Evaporator
 - Electronic paddle-free flow switch. Auto-setting according to cooler size and fluid type.
- Auto-adaptive control
 - Control algorithm prevents excessive compressor cycling
 - Automatic compressor unloading in case of abnormally high condensing pressure or discharge temperature.
- Exceptional endurance tests
 - Partnerships with specialised laboratories and use of limit simulation tools (finite element calculation) for the design of critical components.
 - Transport simulation test in the laboratory on a vibrating table and then on an endurance circuit (based on a military standard)

Safe Design

- Specific polyol ester oil qualified by Carrier for using with HFO-1234ze and R-515B to guarantee and maintain reliable bearing lubrication.
- Specific compressor gaskets compatible with HFO-1234ze and R-515B, tested and validated by Carrier.
- New relief valves designed for operation with HFO-1234ze and R-515B
- New control algorithms
- Specific documentation that contains all the installation, operation, maintenance and safety Instructions.
- No need of electrical cabinet ducted fresh air supply

Easy and fast installation

- Compact design
 - The 30XW-VZE/30XWHVZE units are designed to offer compact dimensions for easy installation.
 - With a width of approximately 1.25 m up to 1000 kW the units can pass through standard door openings and only require minimum floor space in the plant room.
- Simplified electrical connections
 - Transformer supply to the integrated control circuit (400/24 V)
- Simplified water connections
 - Victaulic connections on the evaporator and condenser
 - Practical reference marks for entering and leaving water connections
 - Possibility to reverse the heat exchanger water inlet and outlet at the factory
 - Possibility to modify the number of heat exchanger passes
- Fast commissioning
 - Systematic factory operation test before shipment
 - Quick-test function for step-by-step verification of the instruments, expansion devices and compressors.
 - Non flammable use possible when selecting option 330, Low GWP A1 R-515B Refrigerant

Minimised operating sound levels

- The inverter technology used for the compressor motors minimises noise levels at part load operation. In two-compressor units at 25% of the maximum load the unit sound power level is reduced by 10 dB(A).
- Standard unit features include:
 - Silencers on the compressor discharge line.
 - Sound insulation on the components that are most subjected to radiated noise.
- Option 257 further reduces the global unit sound level.

CUSTOMER BENEFITS

Environmental care



- R-1234ze long-term refrigerant solution
 - HFO refrigerant with nearly zero global warming potential (GWP < 1) and zero ozone depletion potential (ODP = 0).
 - Not impacted by the HFC phase-down plan in Europe (79% HFC reduction in EU member states at 2030 horizon)
 - Compliant with refrigerant regulation in Switzerland that bans the use of HFC refrigerant in large capacity air-conditioning equipment.
- Leak-tight refrigerant circuit
 - Reduction of leaks as no capillary tubes and flare connections are used
 - Verification of pressure transducers and temperature sensors without transferring refrigerant charge
 - Discharge line shut-off valve and liquid line service valve for simplified maintenance.

Designed to support green building design

- A green building is a building that is environmentally sustainable and has been designed, constructed and is operated to minimise the total impact on the environment. The underlying principles of this approach: The resulting building will be economical to operate, offer increased comfort and create a healthier environment for the people who live and work there, increasing productivity.
- The air conditioning system can use between 30 and 40% of the annual building energy consumption. Selection of the right air conditioning system is one of the main aspects to consider when designing a green building. For buildings with a variable load throughout the year 30XW-VZE/30XWHVZE units offers a solution to this important challenge.
- A number of green building certification programs exist in the market and offer third-party assessment of green building measures for a wide variety of building types.
- The following example looks at how Carrier's new 30XW-VZE/30XWHVZE range helps customers involved in LEED® building certification.

30XW-VZE/30XWHVZE and LEED® certification

The LEED® (Leadership in Energy and Environmental Design) green building certification programme is a pre-eminent programme to rate the design, construction and operation of green buildings with points assigned in seven credit categories:

- Sustainable Sites (SS)
- Water Efficiency (WE)
- Energy & Atmosphere (EA)
- Materials & Resources (MR)
- Indoor Environmental Quality (IEQ)
- Innovation in Design (ID)
- Regional Priority (RP).

There are a number of different LEED® products.

While the strategies and categories assessed remain same, the point distribution varies to address different building types and application needs, for example according to New Construction, Schools, Core & Shell, Retail and Healthcare.

All programmes now use the same point scale:

110 Possible LEED® points

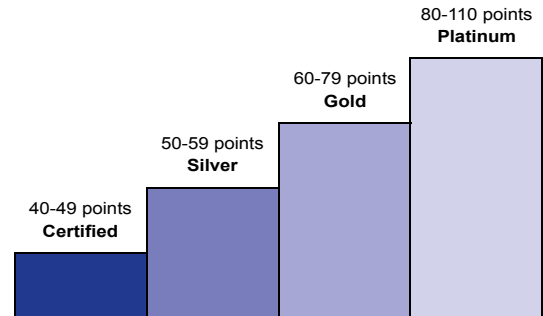

The majority of credits in LEED® rating systems are performance-based and achieving them is dependent on the impacts of each component or sub-system to the overall building.

While the LEED® green building certification programs do not certify products or services, the selection of the right products, systems or service programs is critical to obtain LEED® certification for a registered project, because the right products or service programmes can help meet the goals of green construction and ongoing operation and maintenance.

The choice of heating, ventilating and air conditioning (HVAC) products in particular can have a significant impact on LEED® certification, as the HVAC system directly impacts two categories that together influence 40% of the available points.

Overview of LEED® for new construction and major renovations

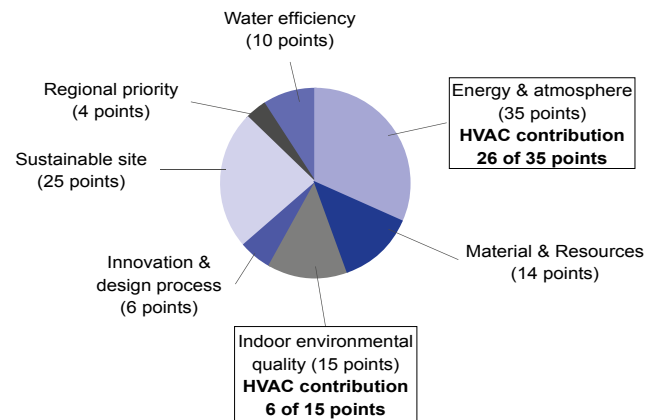

The new 30XW-VZE/30XWHVZE units from Carrier can assist building owners to earn LEED® points in particular in the Energy & Atmosphere (EA) credit category and help address the following prerequisites and credit requirements:

- **EA prerequisite 2: Minimum energy Performance**
The 30XW-VZE/30XWHVZE exceeds the energy efficiency requirements of ASHRAE 90.1-2007; therefore it complies with the prerequisite standard.
- **EA prerequisite 3: Fundamental Refrigerant Management**
The 30XW-VZE/30XWHVZE does not use chlorofluorocarbon (CFC) refrigerants thus satisfying the prerequisite statement.

CUSTOMER BENEFITS

- **EA credit 1: Optimise energy performance (1 to 19 points)**
Points for this credit are assigned depending on the energy cost reduction virtually achievable by the new building, compared to ASHRAE 90,1-2007 reference. The 30XW-VZE/30XWHVZE, which is designed for high performance especially during part load operation, contributes reducing the energy consumption of the building and therefore helps gaining points within this credit. In addition, the Carrier HAP (Hourly Analyses Program) can be used as an energy analyses program complying with the modeling requirements for this credit and produce reports that are easily transferable to LEED® templates.
- **EA credit 4: Enhanced refrigerant management (2 points)**
With this credit, LEED® awards systems that minimise the Ozone Depletion Potential (ODP) and Global Warming Potential (GWP) of the system. The 30XW-VZE/30XWHVZE uses HFO-1234ze refrigerant with Global Warming Potential Index below 1 and therefore contributes toward satisfying this credit under LEED®.

NOTE: This section describes the prerequisites and credit requirements in LEED® for New Construction and is directly related to the 30XW-V-ZE/30XWHV-ZE. Other prerequisites and credit requirements are not directly and purely related to the air-conditioning unit itself, but more to the control of the complete HVAC system.

i-Vu®, Carrier's open control system, has features that can be valuable for:

- EA prerequisite 1: Fundamental commissioning of energy management system
- EA credit 3: Enhanced commissioning (2 points)
- EA credit 5: Measurements and verification (3 points).

NOTE: Products are not reviewed or certified under LEED®. LEED® credit requirements cover the performance of materials in aggregate, not the performance of individual products or brands. For more information on LEED®, visit www.usgbc.org.

TECHNICAL INSIGHTS

SmartVu™

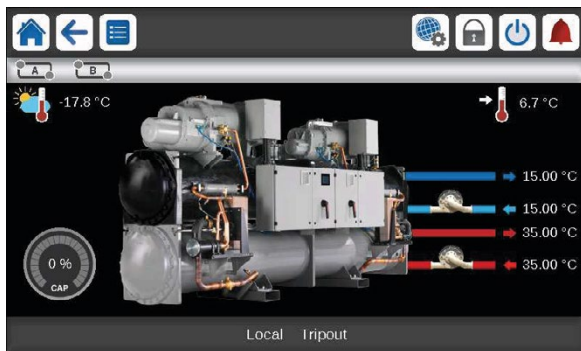

- **New innovative smart control features :**
 - An intuitive and user-friendly, coloured, 7" interface
 - 1 languages available on choice :DE, EN, ES,FR,T,NL,PT, TR, TU + one additional customer choice
 - Screen-shots with concise and clear information in local languages
 - Complete menu, customised for different users (end user, service personnel and Carrier-factory technicians)
 - Setpoint offset based on the outside air temperature
 - Safe operation and unit setting: Password protection ensures that unauthorised people cannot modify any advanced parameters
 - Simple and "smart" intelligence uses data collection from the constant monitoring of all machine parameters to optimise unit operation
 - Night-mode: Cooling capacity management for reduced - noise level.
 - With hydraulic module: Water pressure display and water flow rate calculation.
- **Energy management :**
 - Internal time schedule clock controls chiller on/off times and operation at a second set-point
 - The DCT (Data Collection Tool) records the alarms history to simplify and facilitate service operations.
- **Maintenance functions :**
 - F-Gas regulation leak check reminder alert
 - Maintenance alert can be configured to days, months or hours of operation

- **Advanced communication features :**
 - Easy and high-speed communication technology over Ethernet (IP) to a centralised building management system
 - Access to multiple unit parameters.

Remote Management (Standard)

- Units with SmartVu™ control can be easily accessed from the internet, using a PC with an Ethernet connection. This makes remote control quick and easy and offers significant advantages for service operations
- Aquaforce with Greenspeed® Intelligence is equipped with an RS485 serial port that offers multiple remote control, monitoring and diagnostic possibilities. When networked with other Carrier equipment through the CCN (Carrier Comfort Network - proprietary protocol), all components form a HVAC system fully-integrated and balanced through one of the Carrier's network system products, like the Chiller System anager or the Plant System anager (optional).
- The chiller also communicates with other building management systems via optional communication gateways (BACnet, LON or JBus).
- The following commands/visualisations are possible from remote connection:
 - Start/Stop of the machine
 - Dual set-point management: Through a dedicated contact is possible to activate a second set-point (example, unoccupied mode)
 - Demand limit setting: To limit the maximum chiller capacity to a predefined value
 - Water pump control: These outputs control the contactors of one/two evaporator water pumps.
 - Water pumps changeover (only with hydraulic module options): These contacts are used to detect a water pump operation fault and automatically change over to the other pump.
 - Operation visualisation: indication if the unit is operating or if it is in stand-by (no cooling load)
 - Alarm visualisation.

TECHNICAL INSIGHTS

Remote management (EMM option)

- The Energy management module (EMM) offers extended remote control possibilities:
- Room temperature: Permits set-point reset based on the building indoor air temperature (if Carrier thermostats are installed)
- Set-point reset: Allows reset of the cooling set-point based on a 4-20 mA or 0-10 V signal
- Demand limit: Permits limitation of the maximum chiller capacity based on 0-10 V signal
- Demand limit 1 and 2: Closing of these contacts limits the maximum chiller capacity to two predefined values.
- User safety: This contact can be used for any customer safety loop; opening the contact generates a specific alarm.
- Ice storage end: When ice storage has finished, this input permits return to the second set-point (unoccupied mode).
- Time schedule override: Closing of this contact cancels the programmed time schedule.
- Out of service: This signal indicates that the chiller is completely out of service.
- Chiller capacity: This analogue output (0-10 V) gives an immediate indication of the chiller capacity.
- Alert indication: This volt-free contact indicates the necessity to carry out a maintenance operation or the presence of a minor fault.
- Compressors running status: Set of outputs (as many as the compressors number) indicating which compressors are running.

Remote management (EMM option)

The Energy Management Module offers extended remote control possibilities:

- Room temperature: permits set-point reset based on the building indoor air temperature (with Carrier thermostat)
- Set point reset: ensures reset of the cooling set-point based on a 0-10 V signal
- Demand limit: permits limitation of the maximum chiller power or current based on a 0-10 V signal
- Demand limit 1 and 2: closing of these contacts limits the maximum chiller power or current to two predefined values
- User safety: this contact can be used for any customer safety loop; opening the contact generates a specific alarm
- Ice storage end: when ice storage has finished, this input permits return to the second set-point (unoccupied mode)
- Time schedule override: closing of this contact cancels the time schedule effects
- Out of service: this signal indicates that the chiller is completely out of service
- Chiller capacity: this analogue output (0-10 V) gives an immediate indication of the chiller capacity
- Alert indication: this volt-free contact indicates the necessity to carry out a maintenance operation or the presence of a minor fault.
- Compressors running status : set of outputs (as many as the compressors number) indicating which compressors are running.

New inverter-driven Thunderbolt screw compressor

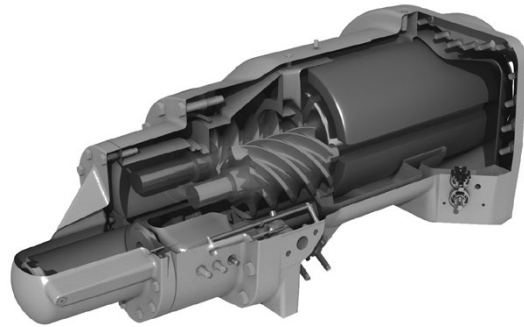

- The Carrier 06T screw compressor designed for operation with HFO-1234ze refrigerant benefits from Carrier's long experience in the development of twin-rotor screw compressors. The design of the Thunderbolt compressors is based on the successful 06T screw compressor, core of the well-known Aquaforce series.
- Advanced control algorithms combine inverter frequency output with motor input logic to minimise mechanical part stress, resulting in best compression performance and high chiller reliability. The compressor is equipped with bearings with oversized rollers, oil pressure lubricated for reliable and durable operation, even at maximum load.
- Screw compressors use positive displacement principle to compress gases at higher pressure. As a result, in case of exceptional high temperature condenser side (due for example to water-pipes fouling or operation in harsh climate with an external dry-cooler) the compressor does not switch off, but continues operation at reduced capacity (unloaded mode).
- The silencer in the discharge line considerably reduces discharge gas pulsations for much quieter operation.
- The condenser includes an oil separator that minimises the amount of oil in circulation in the refrigerant circuit and re-directs it to the compressor function.

OPTIONS

Options	N°	Description	Advantages	Use
Light-brine solution, down to -3°C	8	Implementation of new algorithms of control to allow chilled brine solution production down to -3°C when ethylene glycol is used (0°C with propylene glycol)	Matches with most application requirements for ground-sourced heat pumps and fits with many industrial processes requirements	451-1301 (see dedicated paragraph)
Master/slave operation	58	Unit equipped with supplementary water outlet temperature sensor kit to be field-installed allowing master/slave operation of two units connected in parallel	Optimised operation of two units connected in parrallele operation with operating time equalisation	451-1301
Condenser insulation	86	Thermal condenser insulation	Minimizes thermal dispersions condenser side (key option for heat pump or heat recovery applications) and allows compliancy with special installation criteria (hot parts insulated)	451-1301
Service valve set	92	Liquid line valve (evaporator inlet) and compressor suction line valve	Allow isolation of various refrigerant circuit components for simplified service and maintenance	451-1301
Evaporator with one pass less	100C	Evaporator with one pass on the water side. Evaporator inlet and outlet on opposite sides.	Easy to install, depending on site. Reduced pressure drops	451-1301
Condenser with one pass less	102C	Condenser with one pass on the water side. Condenser inlet and outlet on opposite sides.	Easy to install, depending on site. Reduced pressure drops	451-1301
21 bar evaporator	104	Reinforced evaporator for extension of the maximum water-side service pressure to 21 bar (standard 10 bar)	Covers applications with a high water column evaporator side (typically high buildings)	451-1301
21 bar condenser	104A	Reinforced condenser for extension of the maximum water-side service pressure to 21 bar (standard 10 bar)	Covers applications with a high water column condenser side (typically high buildings)	451-1301
Reversed evaporator water connections	107	Evaporator with reversed water inlet/outlet	Easy installation on sites with specific requirements	451-1301
Reversed condenser water connections	107A	Condenser with reversed water inlet/outlet	Easy installation on sites with specific requirements	451-1301
Lon gateway	148D	Two-directional communication board complying with Lon Talk protocol	Connects the unit by communication bus to a building management system	451-1301
Bacnet over IP	149	Two-directional high-speed communication using BACnet protocol over Ethernet network (IP)	Easy and high-speed connection by ethernet line to a building management system. Allows access to multiple unit parameters	451-1301
Modbus over IP and RS485	149B	Bi-directional high-speed communication using Modbus protocol over Ethernet network (IP)	Easy and high-speed connection by ethernet line to a building management system. Allows access to multiple unit parameters	451-1301
Condensing temperature limitation	150B	Limitation of the maximum condenser leaving water temperature to 45°C	Reduced maximum power input and current absorption: power cables and protection elements can therefore be downsized	451-1301
Control for low cond. temperature systems	152	Output signal (0-10 V) to control the condenser water inlet valve	Simple installation: for applications with cold water at condenser inlet (ex. ground-source, groundwater-source, superficial water-source applications) the signal permits to control a 2 or 3-way valve to maintain condenser water temperature (and so condensing pressure) at acceptable values	451-1301
Energy Management Module	156	EMM Control board with additional inputs/ outputs. See Energy Management Module option chapter	Extended remote control capabilities (Set-point reset, ice storage end, demand limits, boiler on/off command...)	451-1301
Input contact for Refrigerant leak detection	159	0-10 V signal to report any refrigerant leakage in the unit directly on the controller (the leak detector itself must be supplied by the customer)	Immediate customer notification of refrigerant losses to the atmosphere, allowing timely corrective actions	451-1301
Dual relief valves on 3-way valve	194	Three-way valve upstream of dual relief valves on the shell and tubes evaporator	Valve replacement and inspection facilitated without refrigerant loss. Comforms to European standard EN378/BGVD4	451-1301
Compliance with Swiss regulations	197	Additional tests on the water heat exchangers: supply (additional of PED documents) supplementary certificates and test certifications	Conformance with Swiss regulations	451-1301

OPTIONS

Options	N°	Description	Advantages	Use
Compliance with Russian regulations	199	EAC certification	Conformance with Russian regulations	451-1301
Compliance with Australian regulations	200	Unit approved to Australian code	Conformance with Australian regulations	451-1301
Low noise level	257	Evaporator sound insulation	3 dB(A) quieter than standard unit	451-1301
Welded evaporator connection kit	266	Victaulic piping connections with welded joints	Easy installation	451-1301
Welded condenser water connection kit	267	Victaulic piping connections with welded joints	Easy installation	451-1301
Flanged evaporator water connection kit	268	Victaulic piping connections with flanged joints	Easy installation	451-1301
Flanged condenser water connection kit	269	Victaulic piping connections with flanged joints	Easy installation	451-1301
Thermal compressor insulation	271	The compressor is covered with a thermal insulation layer	Prevents air humidity to condensate on the compressor surface	451-1301
EMC classification C2, as per EN 61800-3	282	Additional RFI filters on the unit power line	Reduces electromagnetic interferences. Increase the variable frequency drive (VFD) immunity level according to first environment (so called, residential environment) requirements and allow its compliancy with emissions level required in category C2	451-1301
Fast Capacity Recovery	QM295	New software algorithms to allow quick restart and fast loading while preserving unit-reliability	Full capacity recovery in less than 5 minutes after power failure. Matches requirements of typical critical missions applications	451-1301
Compliance with Morocco regulation	327	Specifics documents according Morocco regulation	Conformance with Morocco regulations	451-1301
Low GWP A1 R-515B refrigerant	330	Unit delivered with R-515B refrigerant charge (A1, GWP 299)		451-1301

PHYSICAL DATA, 30XW-VZE UNITS

30XW-V ZE / 30XWHVZE				451	501	601	651	851	1001	1101	1201	1301
Heating												
Standard unit Full load performances*	HW1	Nominal capacity	kW	523	581	730	780	1017	1157	1304	1450	1555
		COP	kW/kW	6,3	6,14	6,04	5,92	6,27	6,29	6,12	5,74	5,61
	HW2	Nominal capacity	kW	491	544	677	730	955	1081	1211	1344	1452
		COP	kW/kW	4,74	4,6	4,55	4,39	4,73	4,73	4,67	4,42	4,28
	HW3	Nominal capacity	kW	466	508	628	689	906	1007	1122	1242	1367
		COP	kW/kW	3,52	3,41	3,42	3,24	3,51	3,5	3,52	3,39	3,22
Standard unit Seasonal energy efficiency **	HW1	SCOP _{30/35°C}	kWh/kWh	7,64	7,39	7,62	7,57	7,45	7,4	7,17	6,64	6,56
		η _{s heat} _{30/35°C}	%	298	288	297	295	290	288	279	257	254
		SCOP _{47/55°C}	kWh/kWh	5,34	5,3	5,26	5,21	5,31	5,39	5,46	5,17	5,11
	HW3	η _{s heat} _{47/55°C}	%	206	204	202	201	204	207	210	199	197
		P _{rated}	kW	559	614	761	827	1086	1217	1361	1507	1645
Cooling												
Standard unit Full load performances*	CW1	Nominal capacity	kW	448	496	620	660	870	991	1115	1227	1312
		EER	kW/kW	5,53	5,39	5,26	5,14	5,57	5,6	5,47	5,14	5,05
		Eurovent class		A	A	A	A	A	A	A	A	A
	CW2	Nominal capacity	kW	670	728	915	970	1301	1455	1296	1423	1521
		EER	kW/kW	7,88	7,49	7,26	7,14	7,9	7,74	6,19	5,76	5,7
		Eurovent class		A	A	A	A	A	A	A	A	A
Standard unit Seasonal energy efficiency **	SEER _{12/7°C} Comfort low temp.	kWh/kWh	8,12	8,15	8,77	8,37	8,41	8,48	7,48	7,33	7,13	
		η _{s cool} _{12/7°C}	%	322	323	348	332	333	336	296	290	282
	SEPR _{12/7°C} Process high temp.	kWh/kWh	10,49	10,23	10,42	10,03	10,71	10,71	9,66	9,12	9,10	
Sound levels - standard unit												
Sound power level ⁽¹⁾		dB(A)	103	103	103	103	104	104	104	104	104	104
Sound pressure level at 1 m ⁽²⁾		dB(A)	85	85	85	85	85	85	85	85	85	85
Sound levels - standard unit + option 257⁽³⁾												
Sound power level ⁽¹⁾		dB(A)	100	100	100	100	101	101	101	101	101	101
Sound pressure level at 1 m ⁽²⁾		dB(A)	82	82	82	82	82	82	82	82	82	82
Dimensions - standard unit												
Length		mm	3059	3059	3290	3290	4730	4730	4730	4730	4730	4730
Width		mm	1087	1087	1237	1237	1164	1164	1264	1264	1264	1264
Height		mm	1743	1743	1948	1948	1997	1997	2051	2051	2051	2051

- * In accordance with standard EN14511-3:2018
- ** In accordance with standard EN14825:2016, average climate
- HW1 Heating mode conditions: Evaporator entering/leaving water temperature 10°C/7°C, condenser entering/leaving water temperature 30°C/35°C, evaporator and condenser fouling factor 0 m². k/W
- HW2 Heating mode conditions: Evaporator entering/leaving water temperature 10°C/7°C, condenser entering/leaving water temperature 40°C/45°C, evaporator and condenser fouling factor 0 m². k/W
- HW3 Heating mode conditions: Evaporator entering/leaving water temperature 10°C/7°C, condenser entering/leaving water temperature 47°C/55°C, evaporator and condenser fouling factor 0 m². k/W
- CW1 Cooling mode conditions: Evaporator water entering/leaving temperature 12°C/7°C, condenser entering/leaving water temperature 30°C/35°C, evaporator and condenser fouling factor 0 m². K/W
- CW2 Cooling mode conditions: Evaporator water entering/leaving temperature 23°C/18°C, condenser entering/leaving water temperature 30°C/35°C, evaporator and condenser fouling factor 0 m². K/W
- η_{s heat}_{30/35°C} & SCOP_{30/35°C} Values calculated in accordance with EN14825:2016
- η_{s heat}_{47/55°C} & SCOP_{47/55°C} Values calculated in accordance with EN14825:2016
- η_{s cool}_{12/7°C} & SEER_{12/7°C} **Bold values compliant to Ecodesign regulation: (EU) No 2016/2281 for Comfort application**
- SEPR_{12/7°C} **Bold values compliant to Ecodesign regulation: (EU) No 2016/2281 for Process application**
- (1) In dB ref=10⁻¹² W, (A) weighting. Declared dualnumber noise emission values in accordance with ISO 4871 (with an associated uncertainty of +/-3dB(A)). Measured in accordance with ISO 9614-1 and certified by Eurovent.3dB(A). Measured in accordance with ISO 9614-1 and certified by Eurovent.
- (2) in dB ref 20μPa, (A) weighting. Declared dualnumber noise emission values in accordance with ISO 4871 (with an associated uncertainty of +/-3dB(A)). For information, calculated from the sound power level Lw(A).
- (3) Option 257 = Low noise level
- (4) Weight shown is guideline only. To find out the unit refrigerant charge, please refer to the unit nameplate



Eurovent certified values

PHYSICAL DATA, 30XW-VZE UNITS

30XW-V ZE / 30XWHVZE		451	501	601	651	851	1001	1101	1201	1301
Operating weight⁽⁴⁾	kg	3223	3261	4263	4267	7477	7553	7731	7932	7970
Compressors		Semi-hermetic 06T screw compressors, 60 r/s								
Circuit A	-	1	1	1	1	1	1	1	1	1
Circuit B	-	-	-	-	-	1	1	1	1	1
Oil - standard unit		HATCOL-4496								
Circuit A	l	20	20	25	25	20	20	25	25	25
Circuit B	l	-	-	-	-	20	20	20	25	25
Refrigerant - standard unit		R1234ze (E)								
Circuit A	kg	130	130	180	175	120	120	115	115	110
	teq CO ₂	0,9	0,9	1,3	1,2	0,8	0,8	0,8	0,8	0,8
Circuit B	kg	-	-	-	-	120	120	120	115	110
	teq CO ₂	-	-	-	-	0,8	0,8	0,8	0,8	0,8
Capacity control		SmartVu™, inverter-driven compressor, electronic expansion valve (EXV)								
Minimum capacity	%	20	20	20	20	10	10	10	10	10
Evaporator		Multi-pipe flooded type								
Water volume	l	106	106	154	154	297	297	297	297	297
Water connections (Victaulic)	in	6	6	8	8	8	8	8	8	8
Drain and vent connections (NPT)	in	3/8	3/8	3/8	3/8	3/8	3/8	3/8	3/8	3/8
Max. water-side operating pressure	kPa	1000	1000	1000	1000	1000	1000	1000	1000	1000
Condenser		Multi-pipe flooded type								
Water volume	l	112	112	165	165	340	340	340	340	340
Water connections (Victaulic)	in	6	6	8	8	8	8	8	8	8
Drain and vent connections (NPT)	in	3/8	3/8	3/8	3/8	3/8	3/8	3/8	3/8	3/8
Max. water-side operating pressure	kPa	1000	1000	1000	1000	1000	1000	1000	1000	1000

(4) Weight shown is guideline only. To find out the unit refrigerant charge, please refer to the unit nameplate

ELECTRICAL DATA

30XW-VZE /30XWHVZE		451	501	601	651	851	1001	1101	1201	1301
Power circuit										
Nominal power supply	V-ph-Hz	400-3-50								
Voltage range	V	360-440								
Control circuit										
24 V via the built-in transformer										
Start-up current⁽¹⁾	A	Negligible (lower than maximum current drawn)								
Maximum power factor⁽²⁾		0,91-0,93	0,91-0,93	0,91-0,93	0,91-0,93	0,91-0,93	0,91-0,93	0,91-0,93	0,91-0,93	0,91-0,93
Cosine phi		> 0,98	> 0,98	> 0,98	> 0,98	> 0,98	> 0,98	> 0,98	> 0,98	> 0,98
Harmonic distortion rate⁽³⁾	%	35-45	35-45	35-45	35-45	35-45	35-45	35-45	35-45	35-45
Maximum power input⁽⁴⁾										
Circuit A	kW	125	157	189	208	125	157	189	189	208
Circuit B	kW	-	-	-	-	125	157	157	189	208
With option 81	kW	-	-	-	-	250	314	346	378	416
Eurovent current draw*										
Circuit A	A	129	148	180	197	129	149	180	180	197
Circuit B	A	-	-	-	-	129	149	149	180	197
With option 81	A	-	-	-	-	258	298	329	360	394
Maximum current draw (Un)⁽⁴⁾										
Circuit A	A	195	245	295	325	195	245	295	295	325
Circuit B	A	-	-	-	-	195	245	245	295	325
With option 81	A	-	-	-	-	390	490	540	590	650
Maximum current draw (Un -10%)⁽³⁾										
Circuit A	A	206	260	313	345	206	260	313	313	345
Circuit B	A	-	-	-	-	206	260	260	313	345
With option 81	A	-	-	-	-	412	520	573	626	690
Maximum power input with option 150B⁽⁴⁾										
Circuit A	kW	106	134	161	177	106	134	161	161	177
Circuit B	kW	-	-	-	-	106	134	134	161	177
With option 81	kW	-	-	-	-	212	268	295	322	354
Maximum current draw (Un) with option 150B⁽⁴⁾										
Circuit A	A	169	213	257	283	169	213	257	257	283
Circuit B	A	-	-	-	-	169	213	213	257	283
With option 81	A	-	-	-	-	338	426	470	514	566
Dissipated power⁽³⁾	W	3000	4200	4700	5300	6000	8400	8900	9400	10600

(1) Instantaneous start-up current.

(2) May vary, based on the short-circuit current/max. current draw ratio of the system transformer. Values obtained at operation with maximum unit power input.

(3) Values obtained at operation with maximum unit power input.

(4) Values obtained at operation with maximum unit power input. Values given on the unit name plate.

* Eurovent unit operating conditions: evaporator entering/leaving water temperature = 12°C/7°C, condenser entering/leaving water temperature = 30°C/35°C. Gross performances, not in accordance with EN14511-3:2013. These performances do not take into account the correction for the proportional heating capacity and power input generated by the water pump to overcome the internal pressure drop in the heat exchanger.

DIMENSIONS/CLEARANCES

30XW-VZE/30XWHVZE 451-651

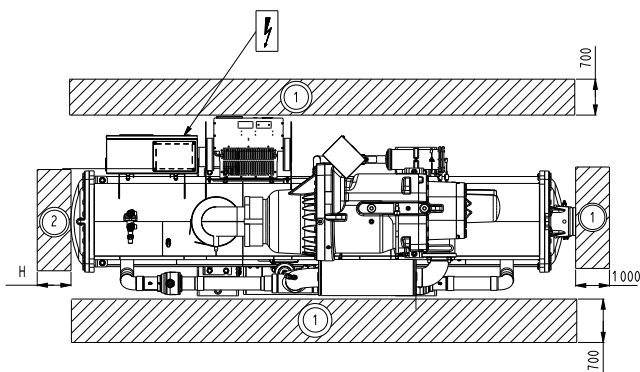
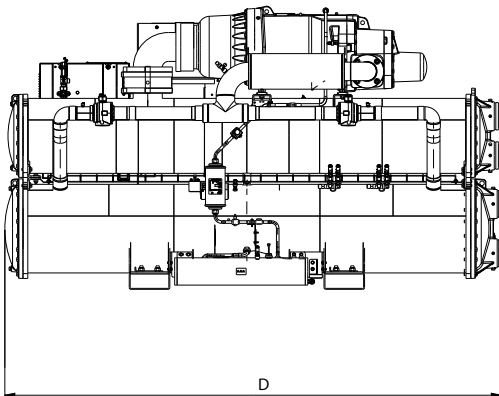
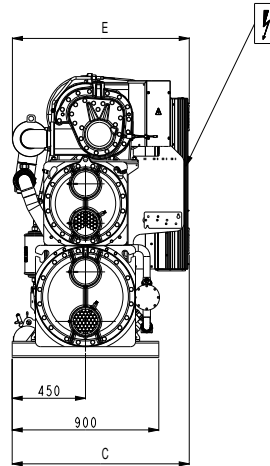
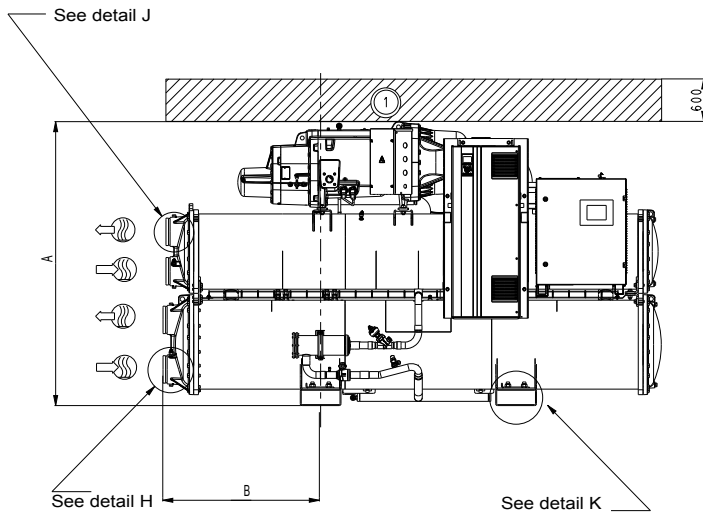

Dimensions in mm								
	A	B	C	D	E	F	G	H
30XW-VZE/30XWHVZE								
451	1743	968	1087	3059	1086	168,3	168,3	2800
501	1743	968	1087	3059	1086	168,3	168,3	2800
601	1948	1083	1137	3290	1237	219,1	219,1	3100
651	1948	1083	1137	3290	1237	219,1	219,1	3100

Legend

All dimensions are given in mm

- ① → Services clearances required
- ② → Space required to remove
- Inlet water
- Outlet water
- Electrical supply entry

NOTES:

Drawings are not contractually binding. Before designing an installation, consult the certified dimensional drawings supplied with the unit or available on request.

For the positioning of the fixing points, weight distribution and centre of gravity coordinates please refer to the dimensional drawings.

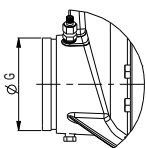

Detail H

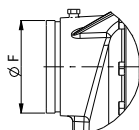

Detail J

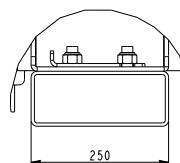

Detail K

DIMENSIONS/CLEARANCES

30XW-VZE/30XWHVZE 851-1301

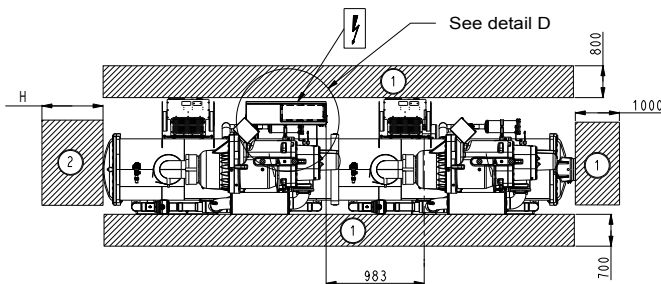
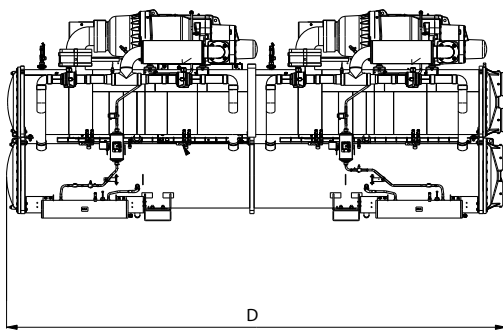
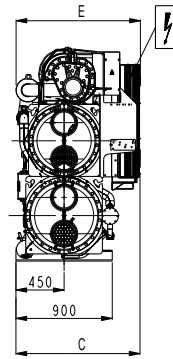
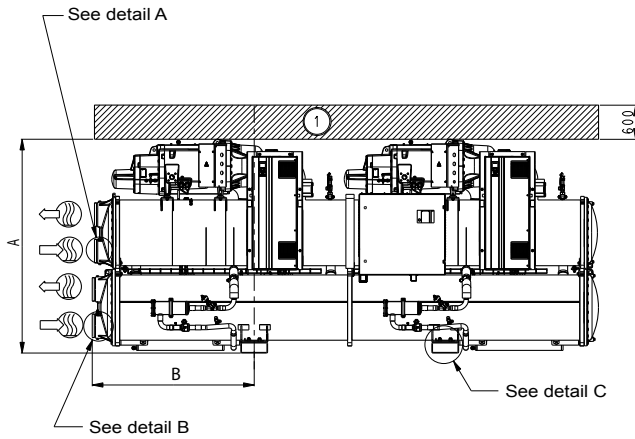

Dimensions in mm								
	A	B	C	D	E	F	G	H
30XW-VZE/30XWHVZE								
851	1998	1514	1164	4730	1162	219,1	219,1	4500
1001	1998	1514	1164	4730	1162	219,1	219,1	4500
1101	2051	1514	1164	4730	1264	219,1	219,1	4500
1201	2051	1514	1164	4730	1264	219,1	219,1	4500
1301	2051	1514	1164	4730	1264	219,1	219,1	4500

Legend

All dimensions are given in mm

- ① → Services clearances required
- ② → Space required to remove
- Inlet water
- Outlet water
- Electrical supply entry

NOTES:

Drawings are not contractually binding. Before designing an installation, consult the certified dimensional drawings supplied with the unit or available on request.

For the positioning of the fixing points, weight distribution and centre of gravity coordinates please refer to the dimensional drawings.

